

Instructions for Geometric Die Sharpening Fixture #001-736

For use with Accu-Finish Series II

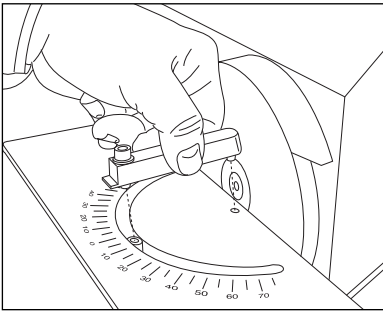

fig. 1

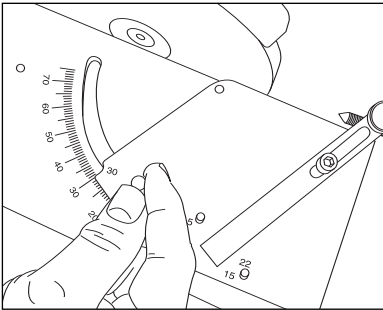

fig. 2

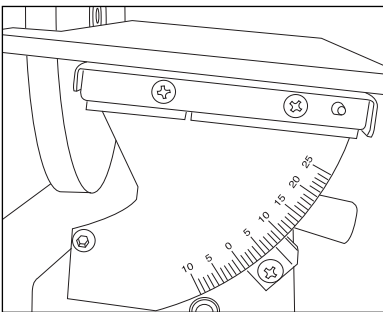

fig. 3

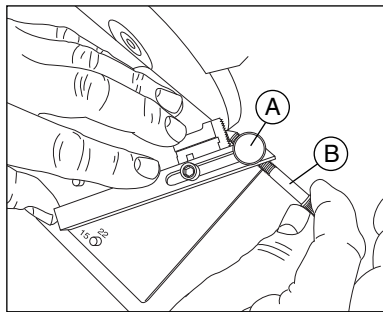

fig. 4

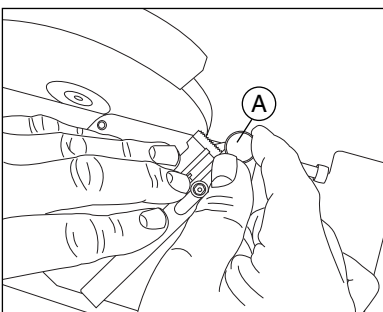

fig. 5

A new low-cost attachment lets anyone resharpen the lead cutting edges of Geometric and similar die chasers on any Accu-Finish Series II sharpener. This attachment insures proper sharpening consistency for all chasers of the same set... a critical requirement for correct threading performance.

An average set of 4 chasers can be resharpened in LESS THAN 5 MINUTES including ALL SET-UP operations. It's easy to use by anyone in your shop. The time and money saved by sharpening your own chasers can justify a complete Accu-Finish Series II, plus this attachment.

SETTING UP YOUR ATTACHMENT

1. Remove protractor guide (fig. 1).
2. Lay die chaser attachment on main table.
 - a. Put front pin in fixed hole.
 - b. Rear pin (with knurled lock screw) goes in the channeled slot (as your protractor guide does).
3. Set the die chaser attachment at 30 degrees. (using inside edge of notch as guide. See Fig. 2).
4. Tighten attachment to main table by tightening the knurled lock screw.

NOTE: Adjust MAIN table as necessary so that the face of the wheel on the right side will be used, and lock your main table down. Fine adjustment can be done later by simply moving as needed.

SETTING ANGLES

1. Set relief angle using elevation scale (generally relief's run from 5 degrees to 10 degrees or duplicate the existing angle on your chasers) (fig. 3).
2. Lock down elevation scale.
3. Set lead in angle.
 - a. Loosen allen head screw.
 - b. Place guide bar over or between appropriate pin (lead angles marked).

ROUGHING IN CHASERS

1. Locate chaser along guide bar (fig. 4).
 - a. Be sure adjustable locating screw "B" is backed out.
2. Slide chaser up the guide bar until face comes in contact with the wheel.
3. Turn locating screw "B" clockwise until it contacts chaser.
4. Turn on grinder (rotating clockwise).
5. Grind chaser face until cleaned up.
 - a. Back out locating screw "B" to do this.
6. When chaser face is cleaned up sufficiently, lock down lock knob "A" (fig. 5).

You are now ready to do remaining chasers, set up is complete. Do not make any additional adjustments while grinding the rest of the set. If an adjustment is made then all previous sharpened chasers should be resharpened.

Accu-Finish®

900 Overlander Road • Emporia, KS 66801

800-835-3519 • Fax 620-343-9640

www.accu-finish.com